

TYPE 1606-A R-F BRIDGE

Section 1

INTRODUCTION

1.1 PURPOSE. The Type 1606-A R-F Bridge (Figure 1) is a null instrument especially useful for accurate measurement of antennas, r-f components, and other circuits having relatively low impedances. The frequency range of the bridge is from 400 kc to 60 Mc. Measurements can be made, with reduced accuracy, at frequencies somewhat above and below the nominal limits. The low-frequency limit is determined mainly by sensitivity considerations, and satisfactory measurements can usually be made at frequencies as low as 100 kc.

1.2 DESCRIPTION.

1.2.1 GENERAL. The bridge is mounted in an aluminum cabinet. Since capacitance between the bridge components and the inside walls of the cabinet comprises one arm of the bridge, the instrument cannot be used outside of the cabinet. For rough usage in field applications, a separate luggage type carrying case is available as an accessory. The bridge can be operated either inside or outside of the luggage case.

1.2.2 CONTROLS. The following controls are on the panel of the instrument (see Figure 2):

<u>Control</u>	<u>Description</u>	<u>Function</u>
REACTANCE	Vernier knob and four-inch dial	Indicates reactance.
RESISTANCE	Vernier knob and six-inch dial	Indicates resistance.
INITIAL BALANCE	Two rotary controls, with locking mechanisms	Used to obtain initial reactance and resistance balance
LOW, HIGH	Two-position toggle switch	Used to establish initial balance setting of the REACTANCE dial in the vicinity of 0 or 5000 ohms.
Capacitors (2)	Adjustments covered by snap buttons	Resistance calibration adjustment.

1.2.3 CONNECTIONS. The following connections are on the panel of the instrument (see Figure 2):

<u>Connection</u>	<u>Description</u>	<u>Function</u>
GEN.	Coaxial connector	Connects generator to bridge.
DET.	Coaxial connector	Connects detector to bridge.
	Binding post	Ground connection to unknown impedance.
	Tapped (6-32) terminal in circular window	Connection for unknown impedance.

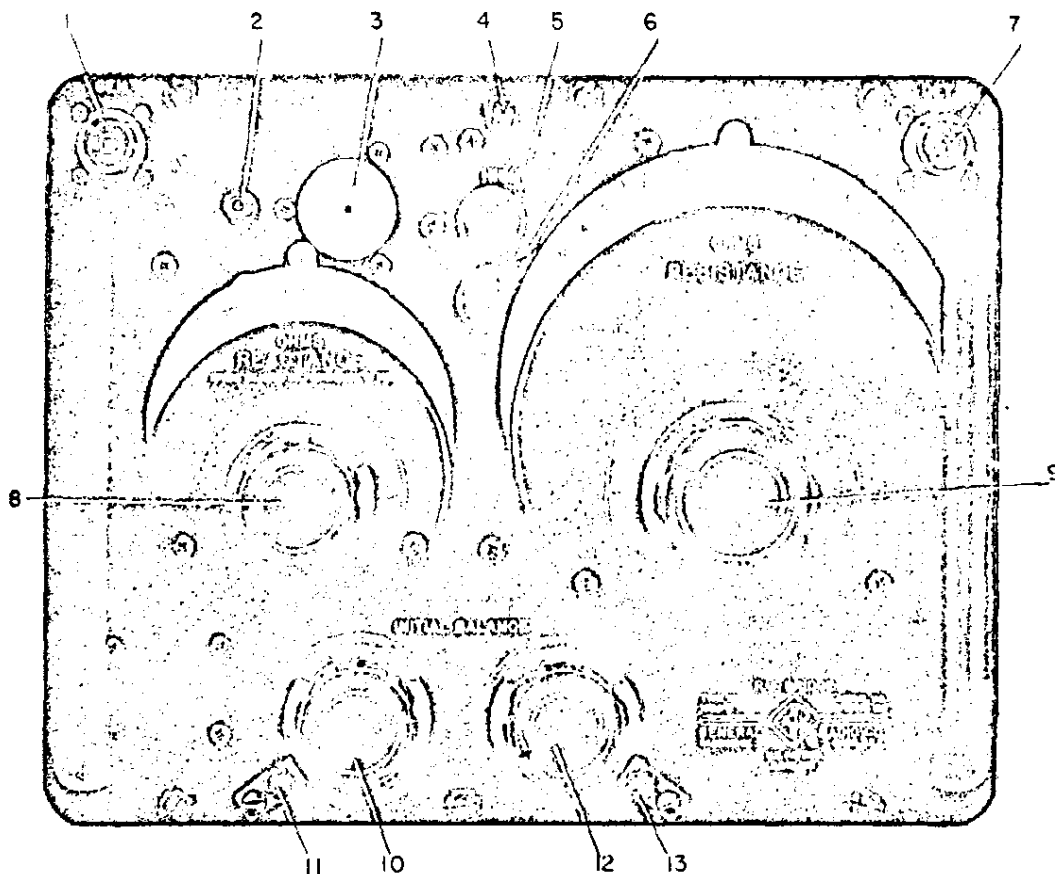

- | | | |
|--|---|---|
| 1. Generator connection | 6. Resistance calibration ad-
justment (LOW range) | 10. Reactance initial-balance
control |
| 2. Ground binding post | 7. Detector connection | 11. Locking mechanism |
| 3. Connection for unknown | 8. Reactance control | 12. Resistance initial-balance
control |
| 4. Initial-balance range switch | 9. Resistance control | 13. Locking mechanism |
| 5. Resistance calibration ad-
justment (HIGH range) | | |

Figure 2. Panel Controls and Connections.

1.2.4 ACCESSORIES SUPPLIED. The following accessories are supplied with the Type 1606-A R-F Bridge:

a. Two clip leads for connecting the unknown impedance to the bridge, one about seven inches long, the other about 27 inches. Each lead has a threaded stud on one end and a clip on the other. Leads are stored in the accessory pouch when not in use.

b. A 3/4-in., 6-32 screw and a spacer 1/4 inch in diameter and 1/2 inch long. These are mounted on the unknown terminal to elevate the connection to the same level as the binding-post mounting hole, so that, if desired, a component can be connected

directly between the ground binding post and the unknown terminal without the use of leads.

c. Two Type 874-R22A Double-Shielded, three-foot Patch Cords for connections to generator and detector. These cords are fitted with Type 874 Coaxial Connectors.

d. One Type 874-PB58A Coaxial Panel Connector for mounting on the detector; if necessary, since for best results the detector should be fitted with a coaxial r-f input connector to complete the continuity of shielding. At higher frequencies the reactance of a binding post or of an inch of wire may cause noticeable error.

Section 2

PRINCIPLES OF OPERATION

2.1 GENERAL CIRCUIT DESCRIPTION AND BALANCE CONDITIONS. The basic circuit of the Type 1606-A R-F Bridge is shown in Figure 3. An initial balance is made with the unknown terminals short-circuited. The short-circuit is then removed, and the bridge rebalanced with the unknown impedance connected to the terminals.

When the terminals are short-circuited, the balance conditions are:

$$R_p = R_b \cdot \frac{C_{a1}}{C_n}$$

and

$$\frac{1}{j\omega C_{p1}} = \frac{R_b}{R_a} \cdot \frac{1}{j\omega C_n}$$

where C_{a1} and C_{p1} are the capacitances of the variable capacitors in the short-circuit balance position. When the short-circuit is replaced by the unknown impedance $Z_x = R_x + jX_x$, the new balance equations are:

$$R_p + R_x = R_b \frac{C_{a2}}{C_n}$$

and

$$jX_x + \frac{1}{j\omega C_{p2}} = \frac{R_b}{R_a} \cdot \frac{1}{j\omega C_n}$$

where C_{a2} and C_{p2} are the capacitances of the variable capacitors with the unknown impedance in the circuit.

The unknown resistance R_x and the reactance X_x are therefore related to the bridge constants by the expressions:

$$R_x = \frac{R_b}{C_n} \cdot (C_{a2} - C_{a1})$$

and

$$X_x = \frac{1}{\omega} \left(\frac{1}{C_{p2}} - \frac{1}{C_{p1}} \right)$$

The resistance R_x is proportional to the change in capacitance C_a , and the reactance X_x depends upon a change in capacitance C_p . The constant that relates resistance R_x to change in capacitance C_a is determined by the fixed resistance R_b and fixed capacitance C_n . The reactance X_x is actually measured by the reactance substitution method, and is

equal and opposite in sign to the change in reactance of the capacitor C_p .

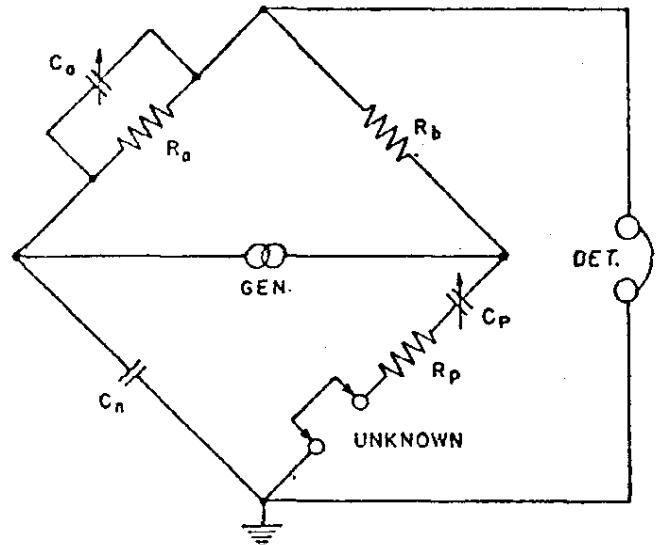

Figure 3. Basic Circuit of the Type 1606-A R-F Bridge.

2.2 DETAILED CIRCUIT DESCRIPTION.

2.2.1 GENERAL. Simple relationships between the unknown resistance, reactance, and increments of capacitance are obtained by the series-substitution method of measurement. For simplicity of operation, auxiliary controls not shown in the basic diagram are added. Their functions are most easily described by separate discussions of the resistance and reactance balances.

2.2.2 RESISTANCE MEASUREMENT. The RESISTANCE dial, which controls variable capacitor C1 (see schematic diagram, Figure 10), can be calibrated in resistive ohms, with any capacitive setting as zero. For the maximum resistance range, this setting is chosen at minimum capacitance. A small variable trimmer capacitor, C2, is then connected in parallel with C1, so that the initial resistance balance, with the unknown terminals short-circuited, can be made at zero dial setting, irrespective of slight changes in the bridge parameters with time or frequency.

2.2.3 REACTANCE MEASUREMENT. The REACTANCE dial, which controls variable capacitor C3, can be calibrated in reactive ohms at any one frequency, again with any capacitance setting as zero.

For the maximum reactance range and the best scale distribution, this setting (dial zero) is chosen at maximum capacitance. A variable trimmer capacitor, C4, is then connected in series with C3, so that the initial reactance balance, with the unknown terminals short-circuited, can be made at zero dial setting or at other points on the dial, irrespective of changes in the bridge parameters with time or frequency.

Another auxiliary control permits the measurement of both capacitive and inductive reactances equally well. With the zero position on the REACTANCE dial established at maximum capacitance, the dial scale reads inductive reactance directly; for measurements of capacitive reactance, the initial balance must be made at an upscale reading so that the negative change in dial reading will remain on scale. Since the range of adjustment of the INITIAL BALANCE control does not permit initial balances to be established over the entire scale, a two-position (LOW, HIGH) switch is provided to shift the initial-balance adjustment range to either

the top or bottom end of the dial by changing the value of the ratio-arm resistor (R1-R2). With this switch in the LOW position, initial balance can be obtained with the REACTANCE dial set from zero to about 100 for the measurement of inductive reactances and relatively small capacitive reactances. With the switch at HIGH, an initial balance can be obtained in the vicinity of the maximum setting of the REACTANCE dial, for the measurement of large capacitive reactances. The unknown reactance equals the difference in the REACTANCE dial reading between the two balances divided by the frequency in megacycles, no matter where the dial is set for the initial balance.

2.2.4 CIRCUIT DIAGRAM. Figure 10 is a complete schematic diagram, showing the ratio-arm switch S1 and the two trimmer capacitors C2 and C4. In the instrument, the fixed capacitance C7 is composed chiefly of the capacitance to ground of the shielding system. The small adjusting capacitors, C5 and C6, are used to equalize the capacitance from point A to ground in the two positions of S1.

Section 3

INSTALLATION

3.1 GENERAL. The complete measurement setup usually consists of the Type 1606-A R-F Bridge, a well-shielded radio-frequency oscillator, and a well-shielded radio receiver, which serves as a detector.

3.2 OSCILLATOR. The r-oscillator must be capable of covering the frequency band of 400 kc to 60 Mc (or any desired portion thereof) with a maximum output voltage of between 0.1 and 10 volts. (For measurements on broadcast antennas, the maximum possible oscillator voltage should be used to override interference.)¹ The oscillator should have a coaxial output connector. (The Type 1211-C Unit Oscillator, with a range of 0.5 to 50 Mc, is especially recommended.) Also, the following instruments may be used as signal generators for the frequencies indicated:

<u>Instrument</u>	<u>Range</u>
Type 1210-C Unit R-C Oscillator	20 cps - 0.5 Mc
Type 1215-B Unit Oscillator	50 - 250 Mc
Type 1330-A Bridge Oscillator	5 kc - 50 Mc

¹ See Appendix 1

<u>Instrument</u>	<u>Range</u>
Type 805-D Standard-Signal Generator	16 kc - 50 Mc
Type 1001-A Standard-Signal Generator	5 kc - 50 Mc

3.3 DETECTOR. The receiver should have a sensitivity control, a beat frequency oscillator, a switch to cut out the AVC circuit, and coverage of the frequency band of 400 kc to 60 Mc, or any desired portion thereof. Conventional communication-type receivers are usually satisfactory. For best results, the receiver should be equipped with a coaxial input connector. The Type 874-PB58A Coaxial Panel Connector is supplied as an accessory for installation on receivers not so equipped.

3.4 GROUNDING. When the instrument is used for antenna impedance measurements, it should be grounded at a single point, through a connection of as low reactance as possible. When the instrument is used to measure impedance of components, grounding is usually not required. To facilitate

making the ground connection, a ground clamp is provided on the instrument case. The ground lead should be a short length of copper strip, about an inch wide. In a maintenance shop setup, a satisfactory ground can be made by copper foil covering the top of the bench, even though the bench is physically far removed from ground. If the foil area is large enough, it will usually be found that a connection from it to ground (e.g. through a steam radiator system) will make no appreciable difference in results. The foil area should be at least great enough so that the generator, bridge, and detector can all be placed upon it. Large metal structures, such as relay racks, are also found to be adequate grounds. If the grounding is inadequate, it will usually be found that the instrument panel is at a different potential from the hand of the operator, and that the balance can be changed if the panel is touched.

3.5 STRAY PICKUP. If the bridge panel is at ground potential and the generator and detector panels are not, it is usually an indication of excessive reactance in the connections from the outer conductors of the coaxial leads to the generator and detector panels. Use of the double-shielded, single-conductor coaxial cables supplied, with coaxial connectors on both generator and detector panels, will generally eliminate these differences in potential.

As a check for stray pickup, balance the bridge with the unknown terminals short-circuited and remove the detector cable from the panel jack of the bridge. The detector pickup should be negligible if the generator is adequately shielded. If the outer shell of the cable jack can be touched to the ground shell of the detector connector without significantly increasing the receiver output, no excessive reactance exists. If the detector, when disconnected from the bridge, shows considerable pickup, it is usually an indication of poor shielding in the generator and detector or of energy transfer from the generator to the detector through the power line. The leakage can also be produced by a faulty cable. It is sometimes found, where grounding conditions cannot be carefully controlled, that individual ground connections from the generator, bridge, and detector panels to a common ground point give less pickup and better results than a single common ground to the bridge alone. The use of coaxial cables and connectors at both generator and detector is par-

Key to Figure 4.

- | | |
|---|---|
| A - Short clip lead | I - Bus wire |
| B - Unknown component | J - Strap (recommended at high frequencies) |
| C - Ground binding post | K - Network under test |
| D - Unknown terminal | L - Ground terminal |
| E - Bridge panel | M - Spacer |
| F - Coaxial line | N - Banana pin or Type 874-61-4 Inner Conductor |
| G - Clamp | |
| H - 10-32 screw substituted for panel screw | |

INITIAL BALANCE

FINAL BALANCE

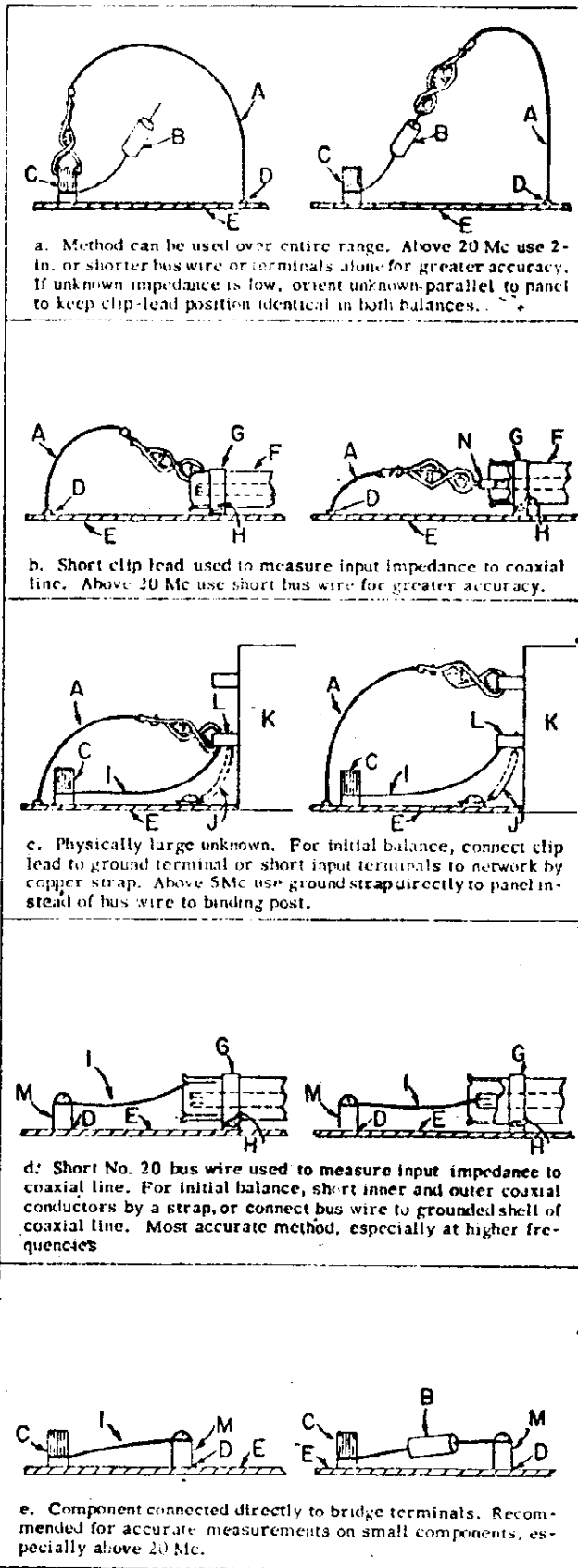

Figure 4. Methods of Connection.

particularly recommended to avoid as much as possible the necessity for such multiple ground connections. In some cases, the effects of stray pickup are reduced if the generator and detector connections are reversed.

For a further check for stray pickup, repeat the procedure described earlier in this paragraph, with the generator cable in place of the detector cable. For antenna measurements, check for coupling between the antenna and the generator or detector by repeating the above checks with the antenna connected to the unknown terminals and the bridge balanced.

3.6 PRELIMINARY ADJUSTMENTS. The following adjustments must be made to prepare the instrument for use:

- a. Connect the generator and detector to the bridge, using the cables and connectors provided.
- b. Ground the equipment if necessary. (Refer to paragraph 3.4.)
- c. Set the generator and detector to the proper frequencies. The input signal should be cw (unmodulated) to prevent possible difficulties arising from side bands.
- d. Connect leads according to paragraph 3.7.

3.7 LEAD APPLICATIONS. The following types of leads should be used for the applications indicated (see Figure 4):

- a. Long clip lead (supplied) - Use only when short lead cannot be used, and then only at frequencies below 5 Mc.
- b. Short clip lead (supplied) - Useful over the frequency range of the bridge. For greatest accuracy, especially at frequencies above 20 Mc, use a two-inch or shorter bus wire or the terminals themselves.
- c. Bus wire leads - A two-inch or shorter lead is recommended, particularly at frequencies above 20 Mc. If longer leads are used at lower frequencies, their capacitances to ground must be measured or estimated (refer to paragraph 4.4).
- d. Bridge terminals - Most accurate measurements result when the unknown impedance can be mounted directly across the bridge terminals.

Use of the terminals alone and terminals with a short bus wire lead also have the advantage of confining the important electrostatic fields to a relatively small area and thus minimizing hand capacitance effects, which may be noticeable when small capacitors are measured.

Section 4

OPERATING PROCEDURE

4.1 INITIAL BALANCE.

4.1.1 PROCEDURE.

- a. Set controls for initial balance as follows:
 - (1) If unit to be measured has an inductive reactance, set switch to LOW, and REACTANCE and RESISTANCE dials to zero and short circuit the unknown terminals.
 - (2) If circuit is known to have a capacitive reactance, set switch to HIGH, REACTANCE dial to 5000, and RESISTANCE dial to zero.
 - (3) If the sign of the reactance is unknown, set switch to HIGH, REACTANCE dial to about 3400, and RESISTANCE dial to zero. The mid-dial setting makes it possible to obtain a balance or at least an indication of the sign of the reactive balance with either inductive or capacitive unknowns.
- b. Balance the bridge to a null by varying the INITIAL BALANCE controls.

4.1.2 LIMITS. At lower frequencies, with the switch at LOW, initial balance can be obtained at REACT-

ANCE settings from zero to about 1200; with the switch at HIGH, from about 3100 to 5000. As the frequency is raised, these reactance limits tend to move up the dial because of the inductive reactance of the connecting lead. Depending upon the length of the connecting lead, a frequency will be found above which initial balance cannot be obtained with the REACTANCE dial at zero and the switch at LOW. A high frequency will be found at which the initial balance can no longer be obtained with the REACTANCE dial at 5000 and the switch at HIGH. The shift in balance causes no corresponding error in measurement since, in the series-substitution process, the constant inductive reactance of the connecting lead cancels out. It does, however, reduce the reactance range of the bridge, since the full coverage of the REACTANCE dial cannot be obtained. The effect can be corrected, when necessary, by the insertion of a small fixed capacitor (about 200 μf) in series with the connecting lead to neutralize the inductive reactance.

TYPE 1606-A R-F BRIDGE

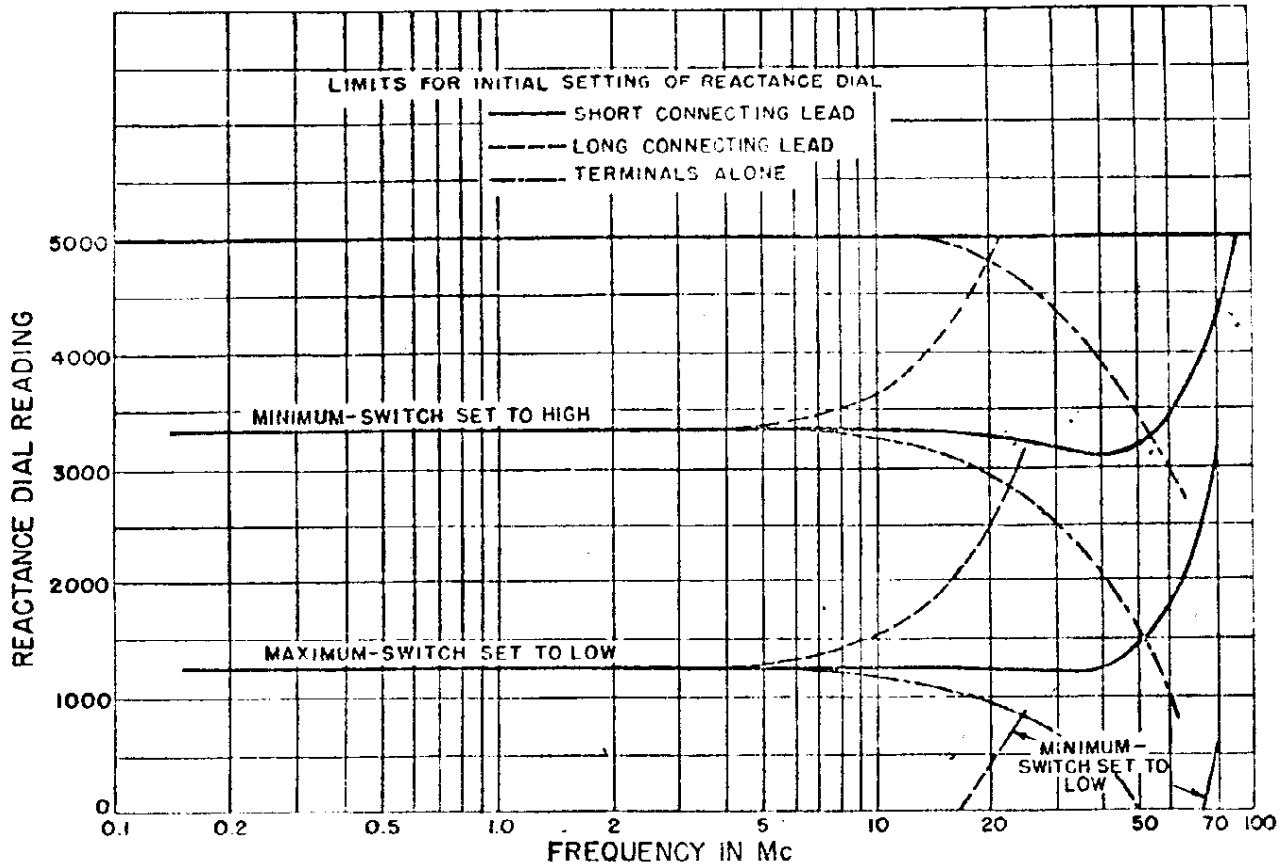

Figure 5. Range of Initial Reactance Dial Setting as a Function of Frequency.

Typical curves of the shifts in initial balance are shown in Figure 5. With the short clip lead, as shown, the shift is relatively small over the entire frequency range of the instrument, and it is usually not necessary to use a series capacitor at any frequency. With the long lead, the shift is appreciable, and at frequencies above 15 or 20 Mc a series capacitor may be necessary. However, the use of the long lead at these frequencies is not recommended as the errors are liable to be fairly large.

When a short bus wire is used for the connecting lead, or when the unknown is connected directly across the bridge terminals, the initial balance range shifts with frequency in the opposite direction from the shift when a clip lead is used (see Figure 5). This reverse shift is caused by compensating reactances, included in the bridge to minimize the initial-balance shift when clip leads are used. At the highest frequencies, the bridge cannot be balanced in the vicinity of 5000 or at zero, but it can be balanced over most of the intermediate range.

4.1.3 NULL DETERMINATION. To balance to a null, adjust the bridge controls until the signal in-

dicated by the detector disappears. Either an aural or a visual indication of signal amplitude may be used. If an aural indication is used, the receiver beat-frequency oscillator should be switched on and tuned to produce an audible beat in the headset. The r-f gain control on the receiver should be set at a level at which the receiver is not saturated. Then, with the receiver AVC off, a rough null should be found. The r-f gain should then be increased, and a more accurate null found. This process should be repeated until the null is located with adequate accuracy. If a visual indication is desired, the S meter on the receiver can be used. (For this purpose, the AVC should be on.) The null can then be determined from a minimum meter reading. The r-f gain control should be set at the maximum level required to obtain a balance with the desired precision of measurement. Usually, the most satisfactory method is a combination of the visual and aural methods, in which the rough balance is made with the headset, with the AVC on. The precise balance should be made with the generator signal unmodulated. The AVC tends to broaden the null, and sometimes makes locating the null more difficult. Therefore, operation of the AVC should be left to the discretion of the operator. If the receiv-

er does not have an adequate r-f sensitivity control, reducing the generator output or detuning the receiver may produce the same general results. For precise balance, the generator output should be set at maximum, so that the ratio of useful output to leakage is as great as possible.

4.2 MEASUREMENT OF UNKNOWN IMPEDANCE WITHIN DIRECT-READING RANGES OF BRIDGE.

a. Connect the ground terminal of the unknown impedance to the bridge panel. Use as short a lead as possible. See Figure 4 for suggested methods of connecting various types of unknowns. (For an inherently grounded impedance, such as a low-frequency antenna, this ground connection can be omitted, since the bridge is already grounded through a low-reactance connection. Refer to paragraph 3.4.) The unknown should be located so that it can be reached with one of the two connecting leads supplied, or with a short bus wire (about No. 20), or connected by its own leads across the unknown terminals.

b. Clip the connecting lead to the ground terminal of the unknown impedance (or short-circuit the terminals of the unknown with a low-inductance strap) and establish an initial balance (refer to paragraph 4.1). If the component is to be connected by means of its own leads between the ground binding post and the unknown terminal, substitute a short bus wire or strapping for the component.

c. Remove the connecting lead from the grounded terminal of the unknown impedance, connect to the ungrounded terminal (or remove the short-circuit from the unknown), and rebalance with the RESISTANCE and REACTANCE controls. The location of the connecting lead should be altered as little as possible when the clip is shifted from the grounded to the ungrounded terminal, in order to minimize the changes in the lead inductance. If the unknown is to be connected by its own leads, substitute the unknown for the bus wire or strapping used for initial balance (refer to step b).

d. Read the unknown resistance directly on the RESISTANCE dial. The unknown reactance equals the change in reading of the REACTANCE dial, for any initial setting, divided by the frequency in megacycles. If the unknown reactance is inductive, the maximum dial-reading accuracy and range is obtained when the initial setting is made at zero.¹

¹When a short bus wire lead or no lead is used, it may not be possible to obtain an initial balance at zero at frequencies above 50 Mc. If initial balance is not obtainable with the switch at LOW, switch to HIGH and obtain an initial balance at the lowest possible REACTANCE dial setting. The measured inductive reactance is then the difference between final and initial REACTANCE dial readings divided by the frequency in Mc.

Under these conditions, the change in reading of the REACTANCE dial equals the final dial reading. If the unknown reactance is capacitive and large in magnitude, the initial setting should be made at 5000 ohms.² The change in reading of the REACTANCE dial then equals 5000 ohms minus the final dial reading.

e. Due to the compression of the REACTANCE scale at the high end, the precision of measurement with the REACTANCE dial initially set at 5000 may not be the highest attainable when a capacitive reactance that produces a dial reading difference of less than 5000 ohms is measured. In such instances, accuracy can be improved by a second measurement of the circuit, with the initial REACTANCE setting slightly higher than the difference in readings obtained in the first measurement. If the desired initial reactance setting lies in the range (see Figure 5) over which initial balance is possible with the switch at LOW, set the switch at LOW for the initial balance. If the desired initial REACTANCE setting is in the range (see Figure 5) in which no initial balance is possible, set the REACTANCE dial near the lowest point at which an initial balance is possible with the switch at HIGH.

f. The following is another method of achieving the same result for capacitive reactances producing less than 1000 ohms differences in the REACTANCE readings:

(1) Set the RESISTANCE dial to the resistance previously measured (as in d., above) and the REACTANCE dial to zero.

(2) Clip the connecting lead to the ungrounded terminal of the unknown impedance.

(3) Obtain an initial balance with the switch at LOW.

(4) Clip the connecting lead to the grounded terminal and rebalance with the RESISTANCE and REACTANCE dials. The REACTANCE dial then reads upscale for capacitive reactance, and the precision of reading is the same as for inductive reactance. This method has the disadvantage of requiring two sets of balances, one to determine the resistive component and the other to determine the reactive component.

g. If it is not known whether the reactive component of the impedance to be measured is inductive or capacitive, the following procedure is helpful: For initial balance, set the switch to HIGH and the REACTANCE dial to the lowest setting at which initial balance is possible (normally not above 3400 ohms). This setting permits a change in scale reading of 1600 ohms inductive or 3400 ohms capacitive.

²When a short bus wire lead or no lead is used, it may not be possible to obtain an initial balance at 5000 at frequencies above 10 Mc. Under these conditions, set the REACTANCE dial at the highest setting at which an initial balance is obtainable.

If the receiver sensitivity is turned down, this available reactance range is sufficient to indicate the approximate magnitude and sign of the unknown reactance, **or**, if the reactance is greater than the above limits, the direction in which the dial must be turned for a reactance balance is indicated, and a new initial balance can be established accordingly.

4.3 MEASUREMENT OF UNKNOWN IMPEDANCE OUTSIDE DIRECT-READING RANGES OF BRIDGE.

If the resistive or reactive component of the unknown impedance falls outside of the direct-reading range of the bridge, indirect measurements can be made through the use of an auxiliary parallel capacitor. When a pure reactance, jX_x , is connected in parallel with the unknown impedance, $Z_x = R_x + jX_x$, and as X_a approaches zero, the effective input impedance, $Z_m = R_m + jX_m$, becomes

$$R_m \cong R_x \frac{X_a^2}{R_x^2 + X_x^2}$$

$$X_m \cong X_x$$

"Shunting down" a high impedance with a parallel capacitor will accordingly bring either or both the resistive and reactive components within the measurement range of the bridge. To measure a high impedance by this method, proceed as follows:

- a. Connect one lead of the auxiliary capacitor to the ground terminal of the unknown impedance, and place the other lead near the ungrounded terminal of the unknown.
- b. Establish an initial balance and measure the capacitive reactance (X_a) of the auxiliary capacitor as described in paragraph 4.2.
- c. Connect the ungrounded lead of the auxiliary capacitor to the ungrounded terminal of the unknown, keeping the capacitor-lead length as near as possible to that used in the measurement with the actual unknown connected.
- d. Measure the effective impedance appearing across the bridge terminals, $Z_m = R_m + jX_m$. Then calculate the unknown impedance from the relations

$$R_x = \frac{R_m}{A} \tag{1}$$

$$X_x = \frac{X_m - \frac{R_m^2}{X_a} - \frac{X_m^2}{X_a}}{A} \tag{2}$$

where

$$A = \left(1 - \frac{X_m}{X_a}\right)^2 + \left(\frac{R_m}{X_a}\right)^2$$

Since the auxiliary reactance (X_a) is capacitive, the number to be inserted for X_a on equations (1) and (2) will be negative. The sign of the effective reactance (X_m) will be positive or negative depending on whether the measured value is inductive or capacitive.

The value of the auxiliary capacitor to be used is easily determined by experiment. It should be kept reasonably small, so that impedances to be measured are not reduced so far that precision of dial reading is lost. A value between 35 and 200 μpf is usually satisfactory. The resistance (R_a) of the auxiliary capacitor is generally negligible, but can be corrected for as follows: Subtract from the effective resistance (R_m) of the parallel combination (capacitor and unknown) a resistance

$$\Delta R = R_a \frac{X_m^2 + R_m^2}{X_a^2}$$

The corrected value of R_m can then be substituted in equations (1) and (2). For example, if, at a frequency of 2 Mc, an auxiliary mica capacitor of approximately 100 μpf is used with the short clip lead, its reactance should be about 800 ohms, corresponding to a difference of 1600 in initial and final REACTANCE dial readings. Since an initial balance cannot be obtained with the REACTANCE dial set at 1600, the dial should initially be set at the lowest practical setting above 1600 at which initial balance is possible. Say this turns out to be 3400, with the switch set at HIGH. The short clip lead is connected to ground and the initial balance is made. Then the clip is connected to the auxiliary capacitor and the bridge is rebalanced with the RESISTANCE and REACTANCE dials. The final readings are 0.5 and 1840, respectively. Therefore:

$$R_a = 0.5 \text{ ohm}$$

$$X_a = \frac{(1840 - 3400)}{2} = -780 \text{ ohms}$$

The circuit to be measured is then connected to the clip lead with the auxiliary capacitor, and to the ground binding post, and the bridge is rebalanced. The final RESISTANCE reading is 115 ohms and the final REACTANCE reading is 2020. Therefore:

$$R_m = 115 \text{ ohms}$$

and

$$X_m = \frac{(2020 - 3400)}{2} = -690 \text{ ohms}$$

(At the higher frequencies, R_m and R_a must be corrected for the effects of inductance in the RESISTANCE capacitor. Refer to paragraph 4.5.)

The correction for the resistance of the auxiliary capacitor is

$$\Delta R = 0.5 \left(\frac{690^2 + 115^2}{780^2} \right) = 0.5 \text{ ohm}$$

The corrected effective resistance, R_m' , is then

$$R_m' = 115 - 0.5 = 114.5 \text{ ohms}$$

The unknown resistance and reactance are calculated from equations (1) and (2) as follows:

$$R_m' = 114.5 \text{ ohms}$$

$$X_m = -690 \text{ ohms}$$

$$X_a = -780 \text{ ohms}$$

$$A = \left(1 - \frac{-690}{-780} \right)^2 + \left(\frac{114.5}{-780} \right)^2 = 0.0349$$

$$R_x = \frac{114.5}{0.0349} = 3281 \text{ ohms}$$

$$x = \frac{-690 - \frac{114.5^2}{-780} - \frac{(-690)^2}{-780}}{0.0349} = -1801 \text{ ohms}$$

For this unknown, somewhat greater accuracy would have been obtained if a 35- μf auxiliary capacitor had been used.

4.4 LEAD CORRECTIONS. In common with other types of impedance-measuring equipment, the bridge can measure impedance only at its own terminals. The residual impedances of the connecting leads often cause this impedance to differ from the impedance appearing at the terminals of the device under test. Under some circumstances, the difference can be ignored and the measured impedance taken as the impedance of the device under test, including the leads. In most instances, however, the device will not be used with the same leads used to connect it to the measuring equipment, and it is necessary to compensate for the effect of the leads to obtain the desired impedance. An exact correction requires an analysis as a transmission line, and the procedure is laborious and cumbersome. Approximate corrections will normally yield satisfactory accuracy.

In paragraph 3.7 it is noted that the length and location of connecting leads to the unknown impedance should be altered as little as possible when the clip is shifted for initial and final balances. This precaution insures that the inductive react-

ance of the leads is very nearly equal under the two conditions, and therefore that it cancels out in the series-substitution process.

It will be remembered that a short bus wire connection is used for initial balance where the unknown is to be connected directly between the bridge terminals. (See Figure 4.) The inductive reactance of this bus wire connection does effect the measurement, since it is removed when the unknown is measured. The reactance of the bus wire should be added (+ reactance) to the measured reactance of the unknown. For No. 20 bus wire, the reactance at 1 Mc is 0.08 ohm, and is directly proportional to frequency. This correction is negligible, except at higher frequencies, and can be reduced to a negligible value at all frequencies by the use of a wide strap rather than a No. 20 bus wire.

The capacitance to ground of a connecting lead will cause errors in measurement that increase as the frequency is raised. Since the capacitance of a connecting lead to ground has the same effect as a capacitance deliberately placed in parallel with the unknown impedance, the correction for its effect can be determined directly from equations (1) and (2), where $Z_m = R_m + jX_m$ is the observed impedance, and X_a the reactance of the lead impedance. If the connecting leads are kept at a reasonable distance from metal objects, say an inch or more at the closest point, their capacitances to ground are approximately as follows:

Terminals and 1/2-in. spacer	2.0 μf
Terminals, 1/2-in. spacer, and 2-in. #20 bus wire	2.5 μf
Short connecting lead	3.8 μf
Long connecting lead	8.3 μf

The reactances corresponding to these capacitances are plotted in Figure 6. For example, if a circuit is measured at a frequency of 5 Mc with the short connecting lead ($X_a = 8500 \text{ ohms}$), and the effective resistance and reactance are 522 ohms and -55.6 ohms, respectively, the true resistance and reactance of the unknown circuit, corrected for the effect of the lead capacitance, are (from equations 1 and 2):

$$A = \left(1 - \frac{-55.6}{-8500} \right)^2 + \left(\frac{522}{-8500} \right)^2 = 0.991$$

$$R_x = \frac{522}{0.991} = 527 \text{ ohms}$$

$$X_x = \frac{-55.6 - \frac{522^2}{-8500} - \frac{(-55.6)^2}{-8500}}{0.991} = -23.4 \text{ ohms}$$

TYPE 1606-A R-F BRIDGE

Figure 6. Capacitive Reactance to Ground of Connecting Leads as a Function of Frequency.

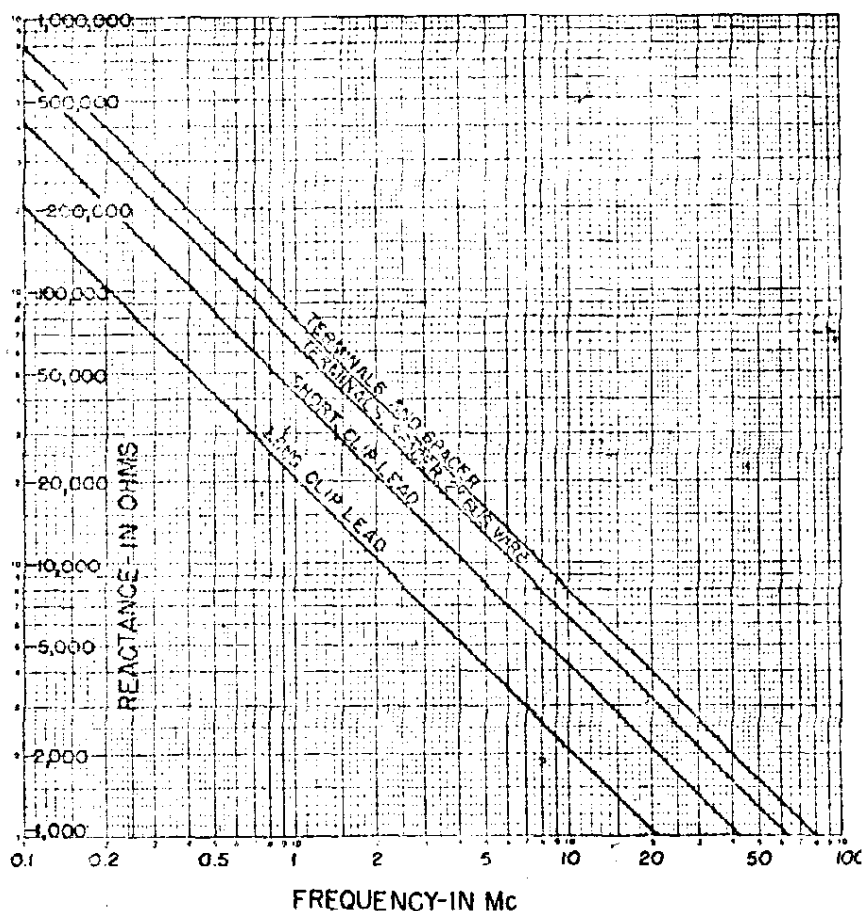

When impedance components are measured outside the direct-reading range of the bridge, no lead corrections are necessary. Precautions in keeping the length and position of the connecting lead as nearly the same as possible insures constant inductance, which cancels out in the series-substitution method; the reactance of the connecting-lead capacitance to ground is included in the measured reactance (X_a) of the parallel capacitor.

It should be noted that the foregoing treatment of lead corrections is approximate. For instance, if the inductive reactance of the connecting lead is comparable to the unknown impedance, the voltage to ground will vary along the lead. Also, the effective capacitance will not be the same as it is when the inductive reactance of the lead is small compared with the unknown impedance. In fact, when the unknown impedance is zero, the effective capacitance to ground of a connecting lead will be only one third of the static value. In compensation, it should be noted, that the lower the unknown impedance, the less the effect of lead capacitance. Obviously, the shorter the connecting lead, the smaller will be the lead corrections. Use the shortest possible connecting lead, therefore, especially at frequencies above 5 Mc. To aid in estimating the

inductive reactance of the leads relative to the unknown impedance, approximate inductance values are as follows:

Short lead	0.14 μ h
Long lead	0.71 μ h
2-in. #20 bus wire	0.025 μ h
1-in. #20 bus wire	0.013 μ h

4.5 CORRECTIONS FOR RESIDUAL PARAMETERS. Frequency limits for accurate $r-f$ impedance measurements are nearly always determined by residual parameters in the wiring and in the impedance elements. While these are extremely small in the Type 1606-A R-F Bridge, they are still large enough to affect performance at the highest frequencies and to set the limit of operation at about 60 Mc.

The low-frequency limit is determined by factors that cause the bridge sensitivity to decrease at the lower frequencies and by compression of the REACTANCE dial calibration. For most applications, satisfactory operation is possible at frequencies as low as 100 kc.

The high-frequency limit is determined by the inductance in the resistance capacitor, C1. This

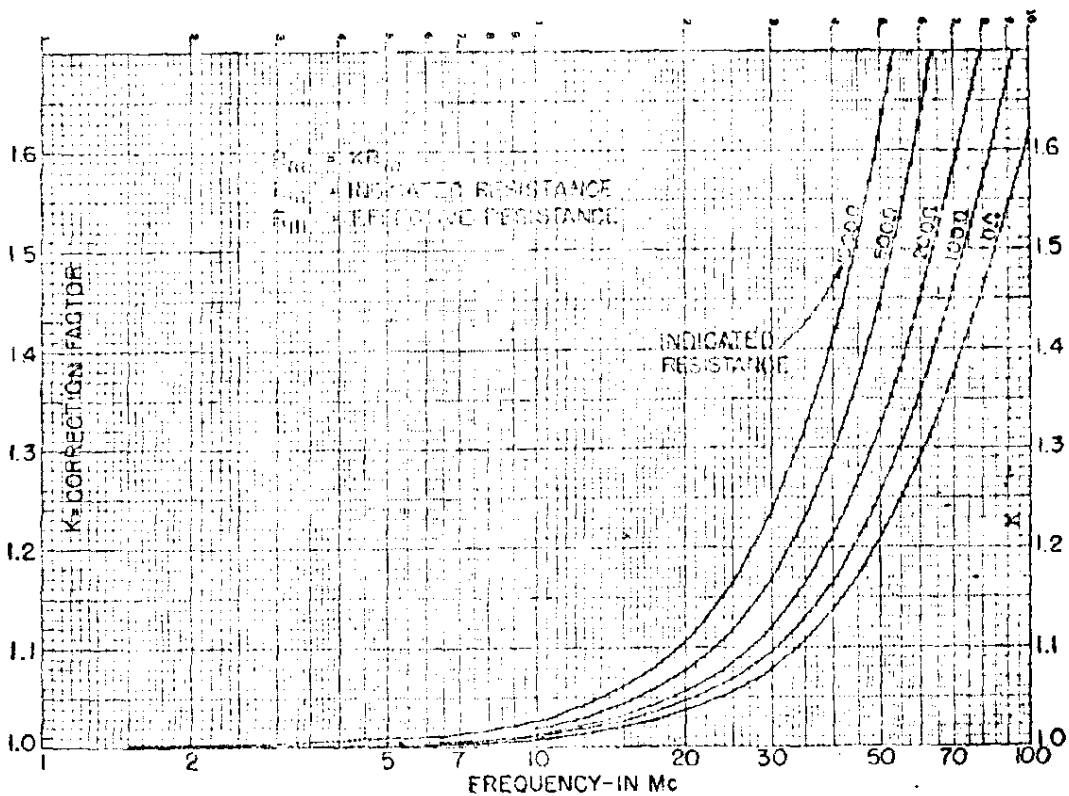

Figure 7. Multiplying Factor for RESISTANCE Dial as a Function of Frequency and Dial Setting (for use with 7-in. connecting lead).

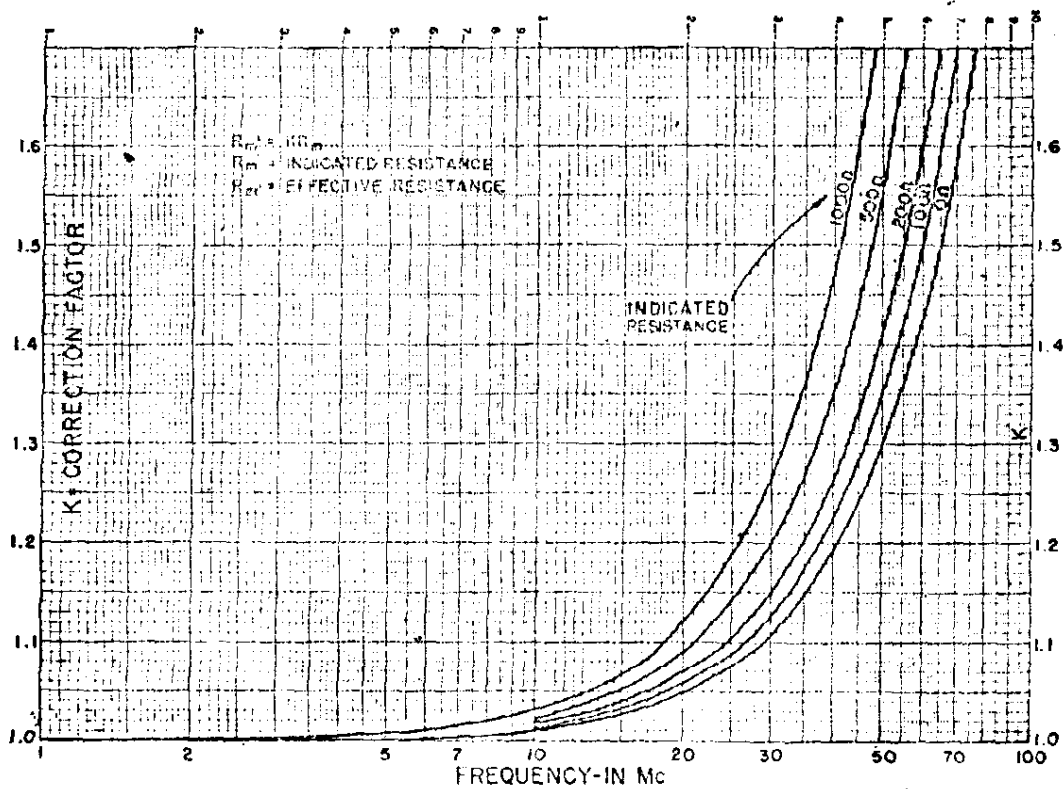

Figure 8. Multiplying Factor for RESISTANCE Dial as a Function of Frequency and Dial Setting (for use with terminals alone or with lead less than 2 inches long).

Inductance causes the effective capacitance to increase as the frequency is raised, and therefore causes the dial reading for a given resistance value to decrease. Correction curves are given in Figures 7 and 8. The correction curve in Figure 8 is the actual correction for inductance in the resistance capacitor, and is valid when the unknown is connected directly across the bridge terminals or by means of a connecting lead less than two inches in length. When the short clip lead is used at

high frequencies, the absorption of the lead inductance in the initial balance causes an error, which is combined with the resistance capacitor inductance error in Figure 8. (Refer to paragraph 6.2c.) For greatest accuracy at the extreme frequency limits, use a short length of bus wire in place of the 7-in. lead supplied, or connect the unknown directly across the bridge terminals. (Refer to paragraph 4.2.)

Section 5

TYPICAL MEASUREMENT PROCEDURES

5.1 GENERAL. The following procedures are given as a guide to the practical application of the bridge.

5.2 MEASUREMENT OF A 100- μ f CAPACITOR AT 500 KC. The unknown impedance in this example is a small mica capacitor of good power factor.

a. Connect the generator and detector. Assume that the short clip lead has been chosen for this measurement. Screw the lead into the unknown terminal, and check for leakage as outlined in paragraph 3.5.

b. Fasten one end of the capacitor to the binding post, and adjust its location so that the clip of the connecting lead can be transferred from the ungrounded capacitor lead to the grounded capacitor lead with a minimum change in the position of the connecting lead. (See Figure 4a.)

c. Since a capacitive reactance is to be measured, the REACTANCE dial will read downscale; hence it must initially be set at a point higher than the expected change in dial reading. Since here the approximate magnitude of the unknown resistance can be estimated from its nominal capacitance, a satisfactory initial REACTANCE dial setting can be easily determined. The unknown reactance in this case is about 3200 ohms, which corresponds to a 1600-ohm change in dial readings. Therefore, from Figure 5, it can be seen that the switch must be at HIGH and the dial at about the lowest setting at which balance is possible, about 3400 ohms. With the clip lead connected to the ground binding post, and the RESISTANCE dial at zero, set up the initial balance using the INITIAL BALANCE controls. The signal should completely disappear at the balance point. If it does not, the reason may be that the REACTANCE dial setting is too low for a balance. If this is the case, move to a slightly higher setting.

d. Transfer the clip of the connecting lead to the ungrounded lead of the capacitor and rebalance with the RESISTANCE and REACTANCE dials. Suppose the readings are 3.2 ohms and 1870 ohms, respectively. Before corrections, the indicated resistance R_m and reactance X_m are:

$$R_m = 3.2 \text{ ohms}$$

$$X_m = \frac{1870 - 3400}{0.5} = -3060 \text{ ohms}$$

e. Since the frequency is very low, the correction for inductance in the RESISTANCE capacitor is negligible.

f. To correct for the connecting-lead capacitance to ground, determine from Figure 6 the reactance X_a of the short connecting lead at 500 kc. It is -84,000 ohms. Applying equations (1) and (2):

$$A = \left(1 - \frac{-3060}{-84,000}\right)^2 + \left(\frac{3.2}{-84,000}\right)^2 = 0.927$$

$$R_x = \frac{3.2}{0.927} = 3.45 \text{ ohms}$$

$$X_x = \frac{-3060 - \frac{3.2^2}{-84,000} - \frac{(-3060)^2}{-84,000}}{0.927} = \frac{-2948}{0.927}$$

$$= -3180 \text{ ohms}$$

g. From these measurements the capacitance and dissipation factor D_x can be found:

$$C_x = \frac{1}{\omega X_x} = \frac{10^2}{2\pi \cdot 0.5 \cdot 10^6 \cdot 3180} = 100 \mu\mu\text{f}$$

$$D_x = \frac{R_x}{X_x} = \frac{3.45}{3180} = 0.00109$$

5.3 MEASUREMENT OF ANTENNA IMPEDANCE AT 1170 KC.

a. Usually an antenna terminal is so located that the bridge cannot be brought close enough to the antenna terminal to permit use of the short connecting lead. Therefore, screw the long connecting lead into the ungrounded bridge terminal.

b. Using the shortest practicable length of copper strap, ground the bridge case to the metal rack in which the antenna terminal is housed. If the connection to the ground clamp on the case cannot conveniently be made, loosen the panel and slide a piece of copper foil into the crack between the panel and the instrument case. Do not ground to panel screws, as they may not be making contact with the panel because of paint. (If desired, an unpainted 10-32 screw can be substituted for one of the panel screws for a ground connection.)

c. Arrange the connecting lead so that it can be clipped to the antenna terminal or the nearest ground point on the rack with as little change in physical location as possible. The lead should be kept away from metal objects throughout its length.

d. Connect the generator and detector, and check for leakage as outlined in paragraph 3.5. For best results, generator and detector should be fitted with completely shielded coaxial connectors.

e. Since the sign and magnitude of the reactance component are unknown, ground the connecting lead to the rack, set the switch to HIGH, the REACTANCE dial to about 3400 ohms, and establish an initial balance using the INITIAL BALANCE controls.

f. Transfer the connecting-lead clip to the antenna terminal and rebalance with the RESISTANCE and REACTANCE dials. Suppose the readings are 193 ohms and 3250 ohms, respectively. On the first measurement it is usually desirable to check for leakage with the antenna connected. Disconnect the generator coaxial connector and observe the signal magnitude with only the outer shells of the connectors making contact. Any signal that appears is a leakage signal. Repeat this procedure with the detector connector. The effect of leakage detected can be estimated by observation of the amplitude of the leakage signal. After reconnecting the generator or detector, determine the shift from balance of either the RESISTANCE or REACTANCE

dial required to produce an unbalance signal equal in amplitude to the leakage signal. The shift in dial reading in ohms is approximately the maximum magnitude of the error. This method does not indicate the distribution of the error between the resistance and reactance measurements.

g. In this measurement the resistance reading is adequately precise, but the reactance reading is not as precise as might be desired because of crowding on the REACTANCE dial scale. For a more precise reactance measurement, initially set the REACTANCE dial nearer to zero, or set the REACTANCE dial to zero and balance the bridge with the antenna connected, using the INITIAL BALANCE controls. If the former method is used, set the REACTANCE dial at a point slightly higher than the difference in REACTANCE readings previously obtained. Since the difference was 150 ohms, set the switch to LOW, REACTANCE to 170, RESISTANCE to zero, clip the connecting lead to ground, and set up an initial balance. Then shift the clip to the antenna terminal and rebalance, using the RESISTANCE and REACTANCE dials. Suppose the readings obtained are 193 ohms and 10 ohms, respectively. Before corrections, the indicated resistance R_m and reactance X_m are:

$$R_m = 193 \text{ ohms}$$

$$X_m = \frac{10 - 170}{1.17} = -137 \text{ ohms}$$

If the latter method is used, leave the RESISTANCE dial set at 193 ohms, and set the REACTANCE dial to zero, with the switch at LOW. Leave the antenna connected and set up an initial balance using the INITIAL BALANCE controls. Transfer the connecting lead clip to ground and rebalance the bridge with the RESISTANCE and REACTANCE dials. The RESISTANCE dial should read zero at balance. Suppose the REACTANCE dial reads 160 ohms. Before corrections, the indicated resistance R_m and reactance X_m are:

$$R_m = 193 \text{ ohms}$$

$$X_m = \frac{0 - 160}{1.17} = -137 \text{ ohms}$$

h. For most accurate results, corrections must be made for effects of the connecting-lead capacitance to ground. From Figure 6, the corresponding reactance (X_a) of the long connecting lead is -16,400 at 1.17 Mc. The corrected impedance can then be obtained from equations (1) and (2).

$$A = \left(1 - \frac{-137}{-16,400}\right)^2 + \left(\frac{193}{-16,400}\right)^2 = 0.984$$

$$R_m = \frac{193}{0.984} = 196 \text{ ohms}$$

$$X_x = \frac{-137 - \frac{193^2}{-16,400} - \frac{(-137)^2}{-16,400}}{0.984} = -136 \text{ ohms}$$

5.4 MEASUREMENT OF A 50-OHM LINE TERMINATED IN ITS CHARACTERISTIC IMPEDANCE AT 50 MC. At very high frequencies, lead corrections are very important. It is also desirable, if possible, to bring up the outer conductor of the coaxial line over the panel and make contact either with the panel directly or with a clamp placed under one of the panel screws. (One of the black panel screws supplied must be replaced with an unpainted 10-32 screw for this application.) (See Figure 9.)

a. Connect the generator and detector, and check for leakage as outlined in paragraph 3.5. At high frequencies, reliable measurements cannot be made unless both the generator and detector are fitted with coaxial connectors.

b. As indicated in paragraph 3.7, either the short clip lead or a short length of No. 20 bus wire can be used for connection to the unknown. Assume that the short clip lead is used for this measurement.

Remove the lead into the ungrounded bridge terminal and clip it to ground directly at the end of the coaxial line under test. (See Figure 4b.) The reactance of any ground connection used is therefore included in the initial balance and is not measured as part of the unknown.

c. Since the line is terminated in its characteristic impedance, the measured reactance will be low. Therefore, the REACTANCE dial should initially be set in the lower part of its range, say at 500 ohms, with the switch at LOW. Establish initial balance using the INITIAL BALANCE controls.

d. Transfer the connecting-lead clip to the center conductor of the coaxial line and rebalance with the RESISTANCE and REACTANCE controls. Suppose the readings are 40.5 ohms and 350 ohms, respectively. Before corrections, the indicated resistance R_m and reactance X_m are:

$$R_m = 40.5 \text{ ohms}$$

$$X_m = \frac{350 - 500}{50} = -3.0 \text{ ohms}$$

For a slightly more precise reactance reading, repeat the measurement, with the REACTANCE dial initially set closer to zero.

e. To correct for inductance in the resistance capacitor, determine from Figure 7 the correction

for a dial reading of 40.5 ohms at 50 Mc. It is 1.23. The corrected value of resistance then becomes:

$$R_m' = 40.5 \cdot 1.23 = 49.8 \text{ ohms}$$

f. To correct for the capacitance to ground of the connecting lead, determine from Figure 6 the corresponding reactance (X_d) of the short clip lead at 50 Mc. It is -838 ohms. Applying equations (1) and (2) to determine the actual line input impedance, Z_x ,

$$A = \left(1 - \frac{-3}{-838}\right)^2 + \left(\frac{49.8}{-838}\right)^2 = 0.996$$

$$R_x = \frac{49.8}{0.996} = 50.0 \text{ ohms}$$

$$X_x = \frac{-3.0 - \frac{49.8^2}{-838} - \frac{(-3)^2}{-838}}{0.996} = 0 \text{ ohms}$$

g. This example is cited as an extreme case, in which failure to correct for the inductance of the resistance capacitor leads to an error in resistance measurement in the order of 20 percent.

5.5 MEASUREMENT OF BALANCED CIRCUITS. The Type 1606-A R-F Bridge will not measure balanced circuits directly. However, the measurement can be made by an indirect method. In the balanced circuit shown in Figure 8a, the following three impedance measurements are required:

Z_1 = impedance between A and ground, B grounded,

Z_2 = impedance between B and ground, A grounded,

Z_3 = impedance between A and B connected together and ground.

The effective components of the balanced network can be calculated from the following equations:

$$Z_{AB} = \frac{2Z_1}{1 + \frac{Z_1}{Z_2} - \frac{Z_1}{Z_3}}$$

$$Z_{BC} = \frac{2Z_2}{1 + \frac{Z_2}{Z_3} - \frac{Z_2}{Z_1}}$$

$$Z_{AC} = \frac{2Z_3}{1 + \frac{Z_3}{Z_1} - \frac{Z_3}{Z_2}}$$

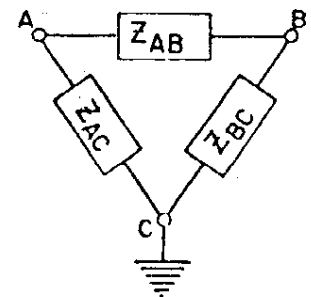

Figure 8a.

If the line is exactly balanced, $Z_{AC} = Z_{BC}$ and $Z_1 = Z_2$.

An auxiliary network to permit direct measurements can be constructed. Details are given in the General Radio Experimenter of September, 1942.

Section 6 CHECKS AND ADJUSTMENTS

6.1 RESISTANCE CALIBRATION. If the RESISTANCE dial calibration changes slightly with time or rough usage, trimmer capacitors C5 and C6, mounted under snap buttons on the panel, can be used to restore calibration. Capacitor C5, under the lower snap button, adjusts the RESISTANCE dial span with the switch at LOW. Capacitor C6, under the upper snap button, adjusts the RESISTANCE dial span with the switch at HIGH. To check calibration, measure the resistance of a good r-f resistor, preferably the carbon-film type, at 1 Mc. with the switch first set at LOW and then at HIGH. The measured resistances at both switch settings should match the d-c value within one percent. If they do not, adjust C5 and C6. Turning these capacitors clockwise decreases the dial reading for a given resistor, and vice versa. Be sure to readjust the initial balance after each adjustment, as the capacitors affect the initial balance as well as the RESISTANCE dial.

6.2 CORRECTION FOR INDUCTANCE IN RESISTANCE CAPACITOR. The change in effective capacitance of the resistance capacitor (refer to paragraph 4.5) is subject to some variation between instruments. Therefore, direct use of the average correction curves of Figures 7 and 8 may lead to error in the resistance measurement. This error is a constant fraction of the correction percentage, and amounts to maximum of ± 0.2 . That is, if the average correction factor is, say 1.15 (correction percentage = 15%) as determined from Figure 7 or 8, the correction for any individual instrument may be from 1.12 to 1.18. For small corrections, such departures from the average are usually negligible. At the highest frequencies, however, they may be large enough to warrant an individual check on the correction curves.

a. To check the curves of Figure 8, measure a good high-frequency resistor, such as a carbon-composition or carbon-film resistor, whose resistance is known to be 50 ohms. a Type 874-WM 50-ohm Termination, or a Type 874-W100 100-ohm Coaxial Standard, at a frequency of 50 Mc with the switch at LOW. Connect the resistor directly across the bridge terminals or use a very short No. 20

bus wire lead. Suppose the measured resistance and reactance of a 50-ohm resistor are:

$$R_m = 37.7 \text{ ohms}$$

$$X_m = \frac{-600}{50} = -12.0 \text{ ohms}$$

b. The actual resistance "seen" by the bridge is the effective series resistance of the parallel combination of the standard resistor and the connecting-lead capacitance. The effective resistance R_e is:

$$R_e \cong \frac{R_x}{1 + \left(\frac{R_x}{X_d}\right)^2} = \frac{50}{1 + \left(\frac{50}{-838}\right)^2} = 49.8 \text{ ohms}$$

(This is an approximation because the effective reactance of the resistor is assumed to have a negligible effect. For accurate results, the resistance value should not exceed 2500 f ohms, where f is the frequency in megacycles.)

The correction factor is equal to the ratio:

$$K = \frac{R_e}{R_m} = \frac{49.8}{37.7} = 1.32 \quad (3)$$

c. The correction factor for this particular instrument can be obtained for any resistance setting from this one measurement through the relation:

$$\frac{R_m'}{R_m} = K = 1 + A(R_m + 560)f^2$$

where f is the frequency in megacycles, R_m' is the effective resistance of the unknown across the bridge terminals (that is, the effective series resistance of the parallel combination of the unknown impedance and the capacitance of the bridge leads and terminal), and R_m is the resistance read from the RESISTANCE dial. Therefore:

$$A = \frac{K - 1}{(R_m + 560)f^2}$$

For the example given:

$$A = 2.13 \cdot 10^{-7}$$

$$\text{and } K = 1 + 2.13 (R_m + 560)f^2 \cdot 10^{-7}$$

A complete set of curves can now be drawn for the particular instrument, either by computation of points from equation (3), or by finding the frequency at which the average correction of Figure 8 agrees with the observed correction and multiplying all frequencies by the ratio of this frequency to the measurement frequency.

Assume that, for a 100-ohm resistor at 50 Mc, K is found to be 1.31. Figure 8 shows a correction factor of 1.31 at about 48 Mc, for a 77-ohm indicated resistance. If all frequencies are multiplied by the ratio 48/50 or 0.96, the curve of Figure 8 may be used directly, or a new set of curves may be drawn with a correct frequency scale.

d. To check the curves of Figure 7, which are used when the short clip lead is used, the same procedure can be used, except that the clip lead must be used for the connection to the unknown.

$$\frac{R_m}{R_m} = K = 1 + B(R_m + 390)f^2$$

$$\text{and } B = \frac{K - 1}{(R_m + 390)f^2}$$

This expression and the K factor differ from those required for the bus wire connection in that they include an effect of the lead inductance not considered in the lead corrections. With the terminals alone or a very short lead, this effect is negligible, but it is significant when the short clip lead is used.

6.3 REACTANCE CALIBRATION. The calibration of the REACTANCE dial is difficult to check ac-

curately, due to the unavailability of capacitance standards that are reliable when mounted on the bridge terminals. However, rough checks can be made as follows:

a. Set the switch to LOW, the REACTANCE dial to its low end, and balance at 1 Mc with the clip lead grounded.

b. Move the REACTANCE dial upscale and try to obtain another null. If the dial is properly oriented with the variable capacitor, no other null will be found.

c. Set the switch to HIGH, the REACTANCE dial to its maximum counterclockwise position (high end of dial), and balance the bridge.

d. Again look for another null. No null should be found, since, if orientation is correct, the variable capacitor will travel slightly less than from its maximum to its minimum capacitance when the dial is rotated from one stop to the other. If two nulls are found, the dial has probably slipped and should be readjusted. To readjust the dial, remove the dial cover, loosen the two set screws locking the dial hub to the shaft, rotate the dial with respect to the shaft, and tighten the set screws.

e. Repeat the search for two nulls and readjust the unit until only one null is found in each case.

For a more accurate check, measure the reactance of several silver-mica capacitors at 1 Mc, and compare the capacitance calculated from the measured reactance ($C = \frac{1}{2\pi fX}$) with the nominal capacitance of the capacitor measured. Be sure to take into account the bridge lead capacitor when making the comparison.

Another method is to measure a capacitor (about 150 μf) whose capacitance is not accurately known, with the REACTANCE dial set at 3400, and again with the dial at 5000. If the calibration is correct and the dial is properly oriented with respect to the capacitor, the measured reactance will be the same for all three measurements. The most likely cause of a change in the REACTANCE dial calibration is slippage of the hub on the dial or one of the gears caused by loose set screws. After locating and tightening the loose set screws, check and adjust the dial as described above.

Section 7

SERVICE AND MAINTENANCE

7.1 GENERAL. The two-year warranty given with every General Radio instrument attests the quality of materials and workmanship in our products. When difficulties do occur, our service engineers will assist in any way possible.

In case of difficulties that cannot be eliminated by the use of these service instructions, please write or phone our Service Department, giving full information of the trouble and of steps taken to remedy it. Be sure to mention the serial and type numbers of the instrument.

Before returning an instrument to General Radio for service, please write to our Service Department or nearest district office (see back cover), requesting a Returned Material Tag. Use of this tag will insure proper handling and identification. For instruments not covered by the warranty, a purchase order should be forwarded to avoid unnecessary delay.

7.2 SERVICE.

7.2.1 TROUBLE SHOOTING. The Type 1606-A is a relatively simple instrument, and visual inspection will locate most troubles that may be encountered. The trouble-shooting chart (page 19) lists some troubles that may occur, and corrective measures.

7.2.2 DISASSEMBLY OF RESISTANCE DIAL.**NOTE**

Do not remove the RESISTANCE dial itself unless absolutely necessary, for once it is removed it is difficult to replace it without loss of calibration.

a. Remove cover from panel by removing two screws and lockwashers, below and to the right and left of the shaft opening. This may be done without danger to calibration, as may steps b and c.

b. Remove the knob and plate from the cover by removing two screws and lockwashers from the plate.

c. To separate knob and plate, remove two set screws from the knob.

d. To remove internal ring gear and dial, remove three screws from stop plate.

e. The hub is connected to the capacitor shaft by means of set screws, through an intermediate insulating bushing. The hub is electrically grounded to the panel by three flat springs between the back of the hub and the panel.

7.2.3 RECALIBRATION AND REASSEMBLY OF RESISTANCE DIAL. If the dial has been moved or the calibration lost, recalibrate by measuring the resistance (at any frequency below one megacycle) of various composition resistors whose d-c resistances are accurately known. The measured resistance of each resistor equals its d-c resistance. When replacing the dial, adjust the stops on the gear drive before recalibration, so that they operate slightly before the capacitor reaches the built-in stop at minimum capacitance or the zero end of the dial. To make this adjustment, reorient the gear drive, or, if necessary, loosen the set screws holding the hub to the shaft and rotate the shaft. The set screws are behind the panel at the base of the hub.

To reassemble, simply reverse the disassembly procedure (paragraph 7.2.2). The cover, plate, and knob can be assembled and then mounted as a unit on the dial.

7.2.4 REACTANCE DIAL.**NOTE**

Do not remove the REACTANCE dial unless it is absolutely necessary, for once it is removed it is difficult to replace it without loss of calibration.

The REACTANCE dial has a gear drive similar to that used on the RESISTANCE dial. However, the dial itself cannot be removed without removal of the hub, which is secured to the shaft by set screws. No grounding spring is required.

If the dial is damaged, copy the calibration on a new dial and set the new dial on the shaft as described in paragraph 6.3. The same procedure can be followed if the dial has been removed or if the set screws have slipped. If the calibration is completely lost, roughly calibrate the new dial by measuring the reactance of several silver-mica capacitors (30 to 3000 μf) at 1 Mc. Their approx-

imate reactances can be computed from their nominal capacitances: $X = \frac{1}{2\pi fC}$. Install and adjust the

dial as outlined in paragraph 6.3, and arbitrarily set the zero point near the left-hand end of the range. To determine the point corresponding to the reactance of each capacitor measured, initially set the REACTANCE dial to zero, make the initial balance with the clip lead connected to the capacitor, and make the final balance with the clip lead connected to ground. The final setting in each case equals the reactance of the capacitor and lead measured. Several points can be determined and marked on the dial. The dial is approximately linear in measured capacitance, and a curve can be drawn by means of the measured points and the intermediate points determined.

7.2.5 REMOVAL OF SHIELDS FROM C3 AND C4.

There are three nesting shields around capacitors C3 and C4. They are fastened to 1/4-inch aluminum base plates by 6-32 screws at the ends nearest the panel. To remove the outer shield, unsolder the lead to R3 and disconnect the straps between S1 and the shield and between C1 and the shield. Do not apply any more heat than necessary to R3.

When replacing the shields, pass the lead to R3 through the grommet hole in the shield by soldering a six-inch length of small-diameter bus wire to the end of the lead, threading the small wire through the grommet, and drawing the lead through as the shield is slipped in place.

7.2.6 REMOVAL OF THE TRANSFORMER. The transformer and the panel connector are permanently fastened together, and the panel connector must be removed before the transformer. The outer shield around the reactance capacitor must be partially removed in order to disconnect the transformer secondary lead. Unsolder the center conductor of the secondary line and remove the nut securing the coaxial fitting to the 1/4-inch aluminum base plate. The transformer itself is mounted to the panel by four screws whose heads appear on the front of the panel.

7.2.7 SPLIT GEARS. If the split gears are removed, they should be reassembled with the upper and lower sections offset when gears are meshed, to provide the spring pressure to eliminate backlash. The springs should be extended two to three full teeth on the large gears, and compressed 1-1/2 to two teeth on the small gears.

TROUBLE-SHOOTING CHART

<u>Trouble</u>	Action or Probable Cause
No signal	a. Check generator and receiver connections. b. Check generator and receiver operation by loosely coupling generator to detector or by connecting a voltmeter to bridge end of cable from generator. c. Check frequency band and setting of generator and detector.
Low sensitivity	a. Check cables for short or open circuit. b. Check generator output. c. Check receiver sensitivity and tuning. d. Check bridge circuit for shorts. e. Check transformer by connecting a voltmeter across unknown terminals. Difference between generator voltage and indicated voltage will vary with frequency. At 1 Mc, indicated voltage should be at least one third of generator voltage.
No balance obtainable	a. Clip lead not connected to ground. b. Reactance dial set at point where balance cannot be obtained. (See Figure 5.) c. HIGH-LOW switch at wrong position. d. Unknown impedance beyond direct-reading range of instrument. e. Resistance dial not at zero for initial balance. f. Lead between R4 and ungrounded terminal on panel broken or disconnected. g. One of resistors in bridge burned out. h. Short circuit in a capacitor.
Resistance dial calibration reads about 20% low	Capacitor-C7 open or disconnected.
Balance erratic or noisy	Loose connection or faulty resistor in bridge.
Initial-balance adjustment range shifted	Resistors shifted in value. Check d-c resistances.
Backlash in dials or controls	Check all set screws on shafts.
Bridge balance changes as bridge or various parts of circuit are touched.	Leakage is present. Refer to paragraph 3.5.

GENERAL RADIO COMPANY

Section 8

PARTS LIST

REF. DESIG.	NAME AND DESCRIPTION	LOCATING FUNCTION
C1	CAPACITOR, VARIABLE, AIR DIELECTRIC, plate-meshing type, 30 μf min, 220 μf max, special capacity tuning characteristic, 1000 v a-c peak voltage, shaft adjustment, 270 deg cw rotation of plates. Furnished only as complete assembly. General Radio Co. Part No. 916-30.	OHMS RESISTANCE control
C2	CAPACITOR, VARIABLE, AIR DIELECTRIC, plate-meshing type, 55 μf max, straight line capacity tuning characteristic, 1000 v a-c peak voltage, shaft adjustment, 360 deg continuous rotation, General Radio Co. Part No. 1420-406.	INITIAL BALANCE control
C3	CAPACITOR, VARIABLE, AIR DIELECTRIC, plate-meshing type, 25 μf min, 220 μf max, straight line capacity tuning characteristic, 1000 v a-c peak voltage, extension shaft adjustment, 180 deg ccw rotation, General Radio Co. Part No. 1420-405.	OHMS REACTANCE control
C4	CAPACITOR, VARIABLE, AIR DIELECTRIC, plate-meshing type, 25 μf min, 220 μf max, straight line capacity tuning characteristic, 1000 v a-c peak voltage, extension shaft adjustment, 360 deg continuous rotation, General Radio Co. Part No. 1420-404.	INITIAL BALANCE control
C5	CAPACITOR, VARIABLE, AIR DIELECTRIC, concentric type, 3 μf min, 12 μf max, straight line capacity tuning characteristic, 350 v ac breakdown test voltage, screw-driver adjustment. General Radio Co. Part No. COA-11.	Capacitance to ground equalizer
C6	Same as C5.	Capacitance to ground equalizer
C7	CAPACITOR, FIXED, MICA DIELECTRIC, 15 μf $\pm 10\%$ tolerance, 500 dcwv, General Radio Co. Part No. COU-24.	
J1	CONNECTOR, RECEPTACLE, banana and binding-post type, not polarized, General Radio Co. Part No. BP-10 (11716).	Ground binding post
J2	CONNECTOR, COAXIAL, General Radio Co. Part No. 874-307.	GEN. connector
J3	Same as J2.	DET. connector
R1	RESISTOR, FIXED, FILM, 220 ohms $\pm 1\%$ tolerance, not tapped, 1/2 watt power dissipation, JAN RN20X2200F, General Radio Co. Part No. REF-65.	Ratio-arm resistor
R2	RESISTOR, FIXED, FILM, 90 ohms $\pm 1\%$ tolerance, not tapped, 1/2 watt power dissipation, JAN RN20X900F, General Radio Co. Part No. REF-65.	Ratio-arm resistor
R3	RESISTOR, FIXED, WIRE WOUND, 330 ohms, $\pm 1\%$ tolerance, 1/4 watt power dissipation, not tapped, General Radio Co. Part No. 1606-304.	Fixed bridge resistor
R4	RESISTOR, FIXED, COMPOSITION, 390 ohms, $\pm 5\%$ tolerance, not tapped, 1/2 watt power dissipation, JAN RC20BF391J, Allen-Bradley Co. Part No. 3915.	Fixed bridge resistor in series with unknown component
S1	SWITCH, KNIFE, General Radio Part No. P1606-37 (cannot be installed as a unit, but is made up of separate elements).	HIGH-LOW switch
T1	TRANSFORMER, RADIO-FREQUENCY, 2 windings single-layer wound; inductance, primary and secondary: 25 μh at 100 kc; turns and wire size, primary and secondary: 2 turns No. 28 AWG enamel copper wire; d-c resistance: primary 0.108 ohm, secondary 0.053 ohm, not tapped, no adjustable tuning, General Radio Co. Part No. 1606-32.	Input transformer

TYPE 1606-A R-F BRIDGE

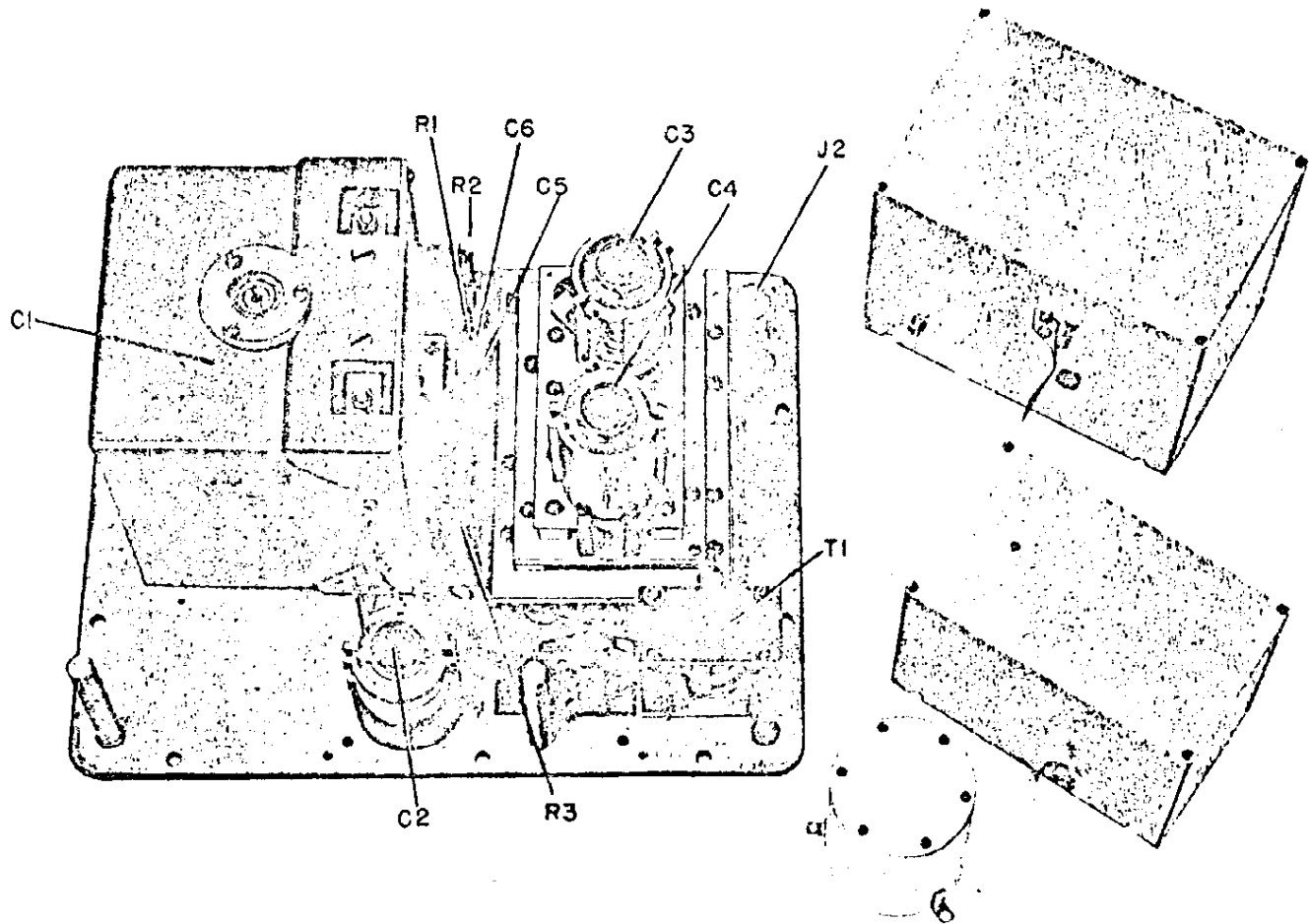

Figure 9. Interior View of Type 1606-A R-F Bridge.

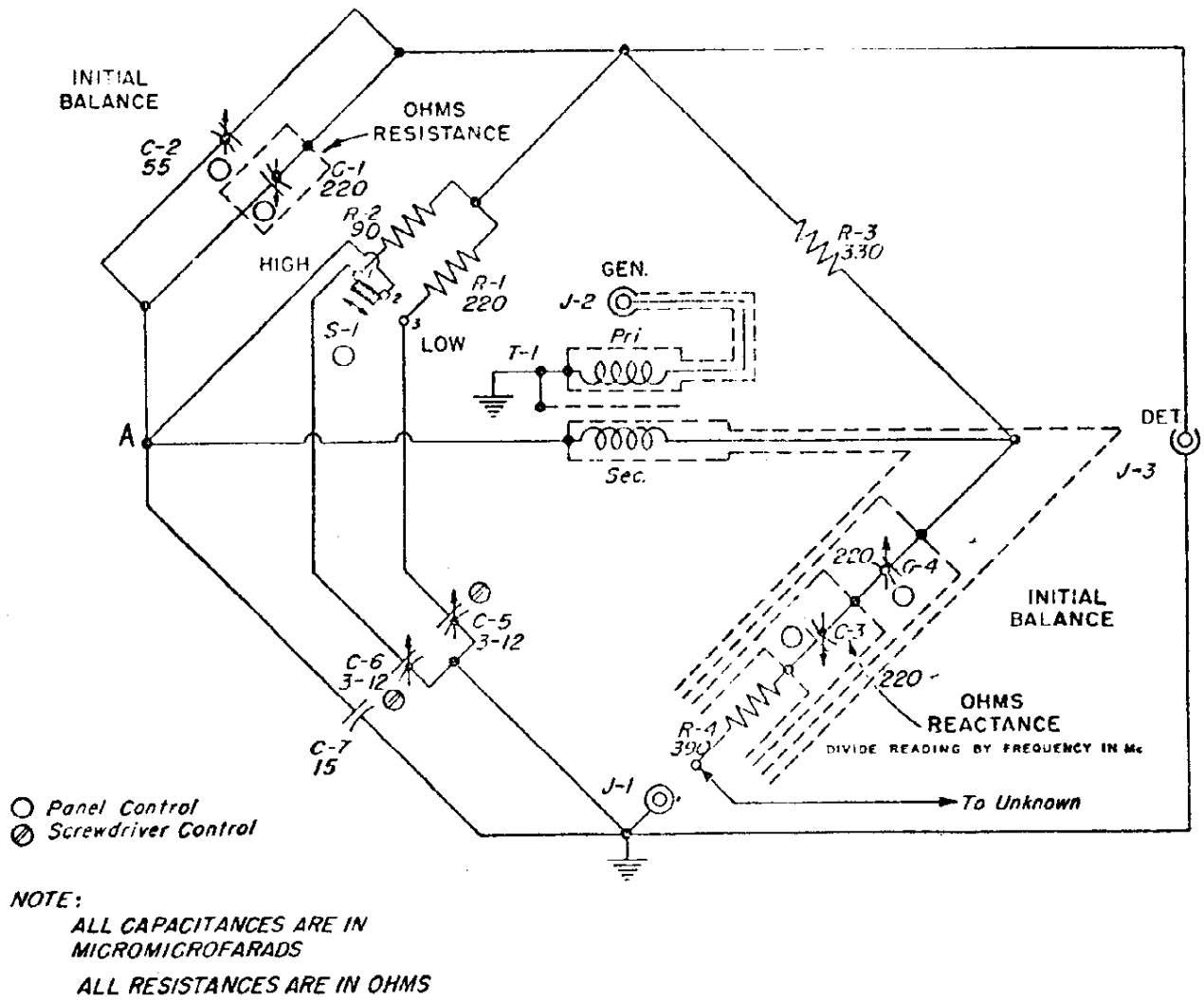

Figure 10. Schematic Diagram of Type 1606-A R-F Bridge.

APPENDIX 1

GENERATOR VOLTAGE LIMITS

The maximum generator voltage that can be safely applied to the bridge varies with frequency and with the setting of the HIGH-LOW switch. Figure 11 shows the limits under various conditions. In antenna measurements, the noise and spurious signals picked up by the antenna under test can cause a significant broadening of the null. In instances where the noise pickup is objectionable, an improvement can often be obtained if the generator and detector connections to the bridge are inter-

changed (generator plugged into DETECTOR connector and detector plugged into GENERATOR connector). If the results are still unsatisfactory, a more selective detector, such as a communications receiver with a crystal filter, should be used or the generator voltage should be increased. As seen in Figure 11, considerably higher voltages can be applied to the bridge when the generator and detector connections are interchanged.

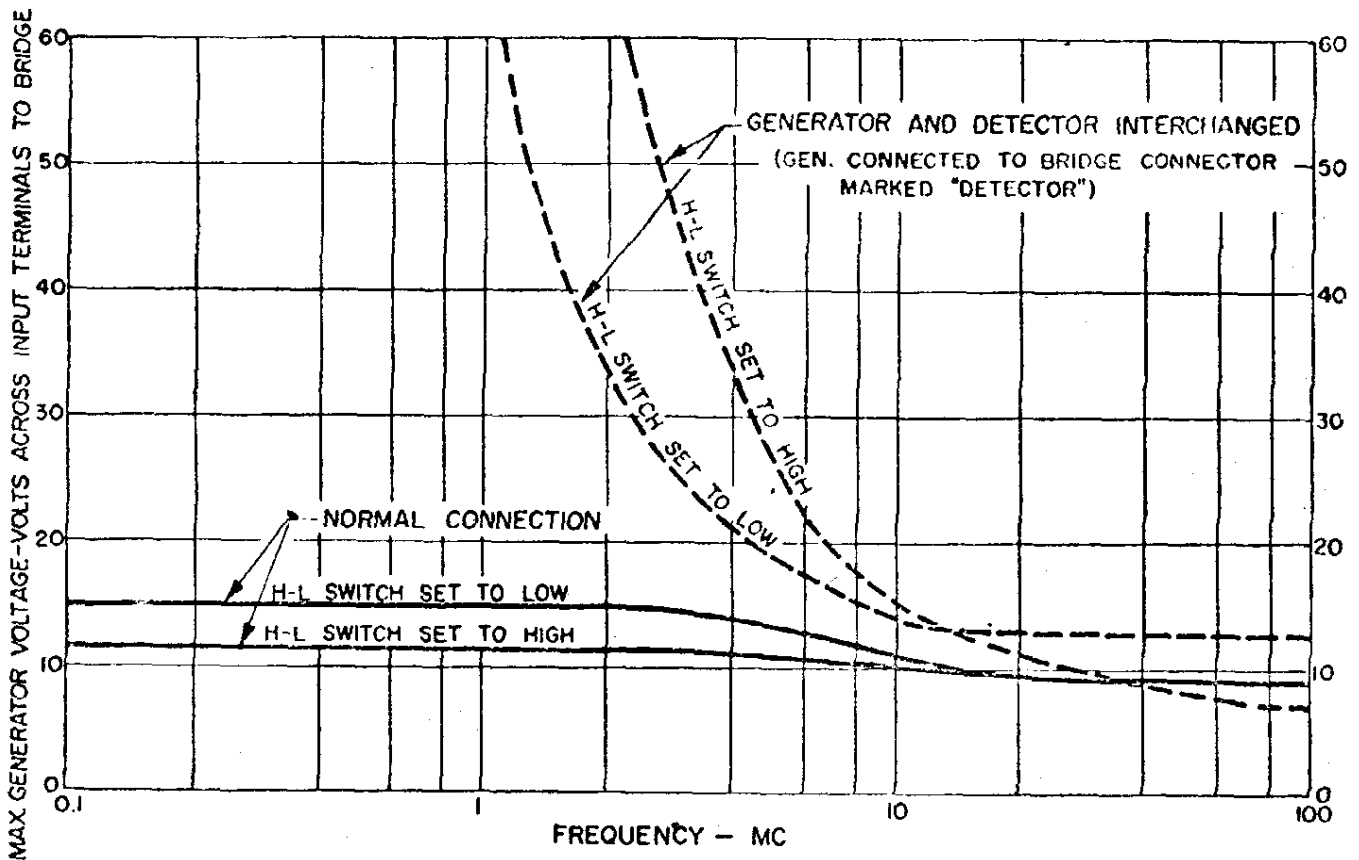

Figure 11. Generator Voltage Limits with Normal and Interchanged Connections.

SODST